

Isometric view
Scale: 1:4

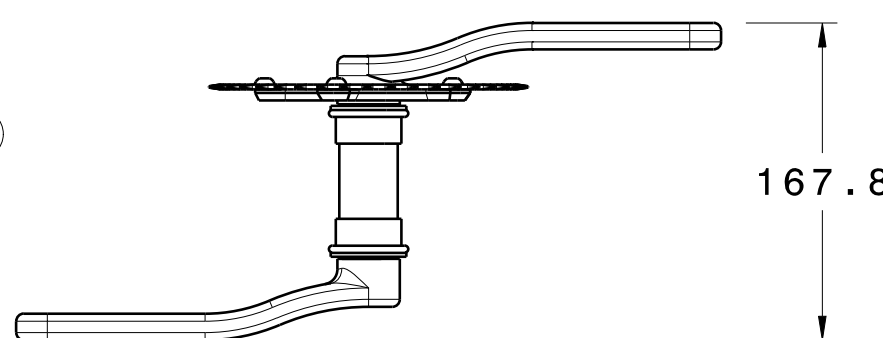

Top view
Scale: 1:4

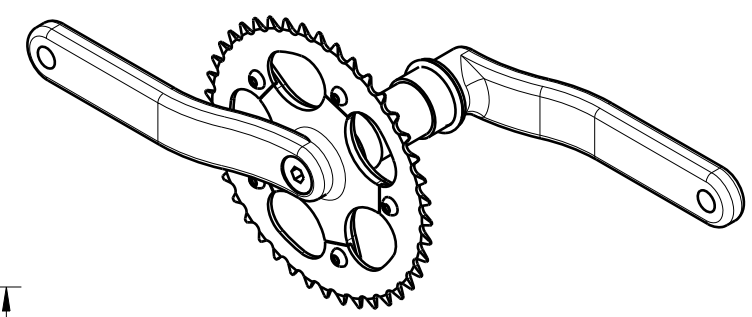

Isometric view
Scale: 1:4

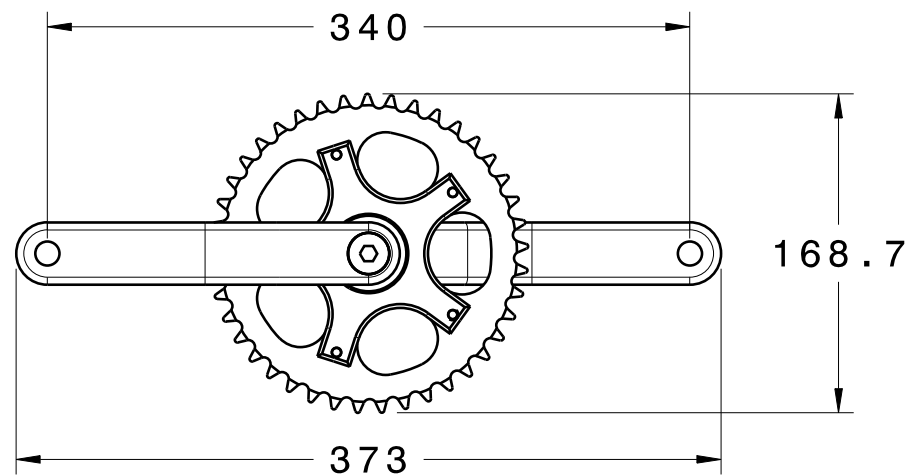

Front view
Scale: 1:4

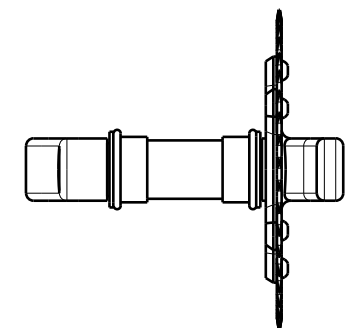

Right view
Scale: 1:4

Bill of Material: CrankSetAssy1

Number	Part Number	Quantity
2	BottomBracketLeftSide1	1
1	BottomBracketMain1	1
3	BottomBracketOring1	2
4	LeftCrank1	1
5	FrontChainring1	1
6	RightCrank1	1
7	M6-1.0x8ButtonHeadSocketCapScrew	5
8	CrankBoltWasher1	2
9	CrankBolt1	2

Unless otherwise specified:
 X.X = ± 0.25
 X.XX = ± 0.13
 X.XXX = ± 0.03
 X° = ± 0.5°

www.StudyCAD.com Standard: ANSI B4.2 (ISO 286)			
DRAWING TITLE			
DRAWN BY Jerimiah	DATE 9/27/2013	SIZE B	DRAWING NUMBER CrankSetAssy1
CHECKED BY XXX	DATE XXX	SCALE 1:4	REV 1
DESIGNED BY XXX	DATE XXX	Units: mm	SHEET 1/1

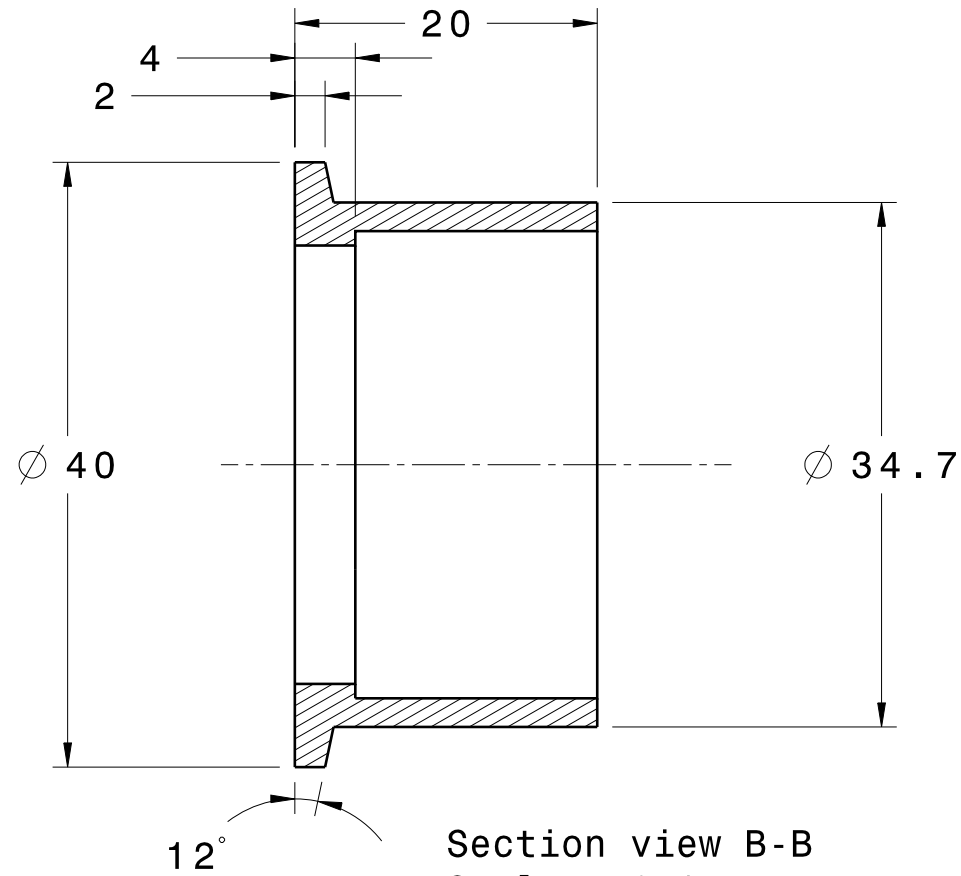

Section view B-B
Scale: 2:1

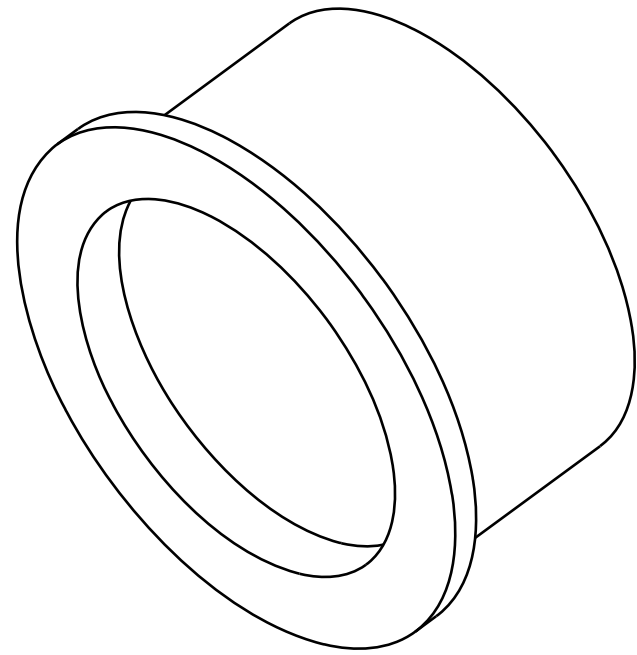

Isometric view
Scale: 2:1

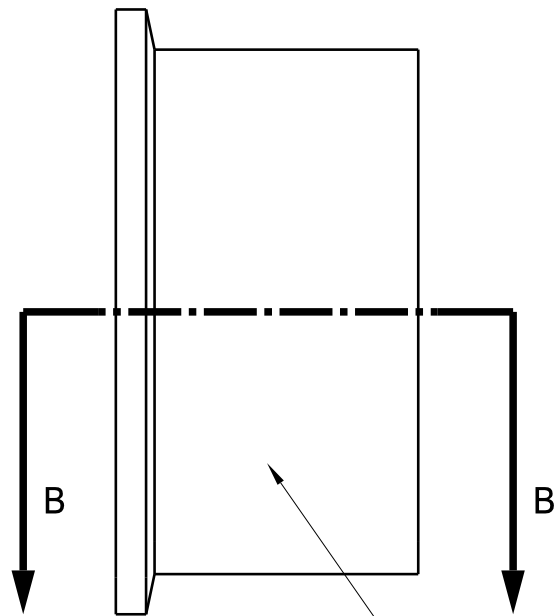

Front view
Scale: 2:1

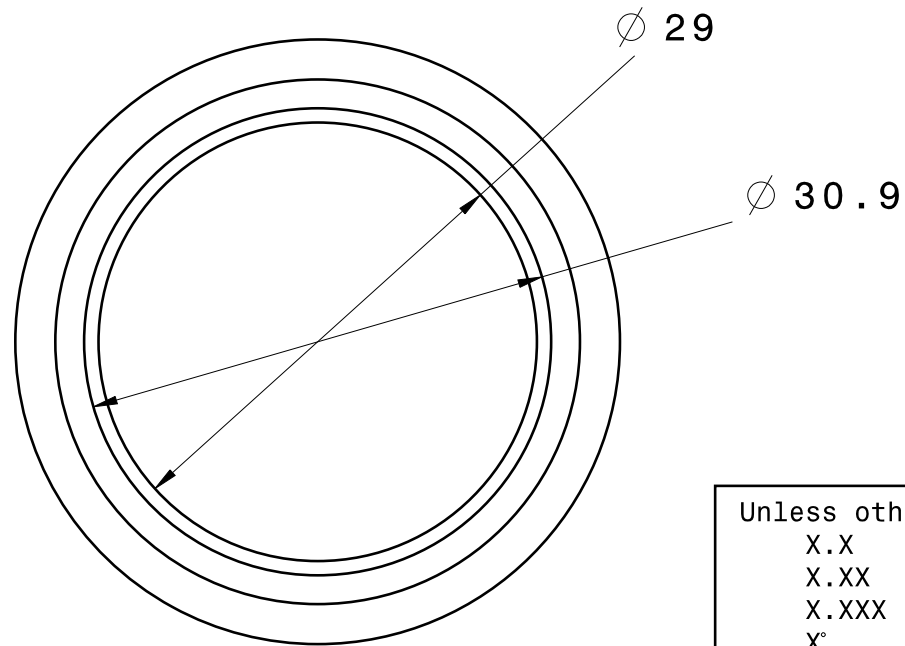

Right view
Scale: 2:1

1.370" -24TPIx0.6"▽-RH

Unless otherwise specified:
 X.X = ± 0.25
 X.XX = ± 0.13
 X.XXX = ± 0.03
 X° = ± 0.5°

www.StudyCAD.com

Standard: ANSI B4.2 (ISO 286)

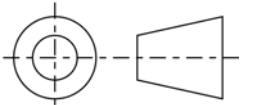

DRAWING TITLE

DRAWN BY
Jerimiah

DATE
9/27/2013

CHECKED BY
XXX

DATE
xxx

DESIGNED BY
XXX

DATE
xxx

SIZE
B

DRAWING NUMBER
BottomBracketLeftSide1

REV
1

SCALE
2:1

Units: mm

SHEET
1/1

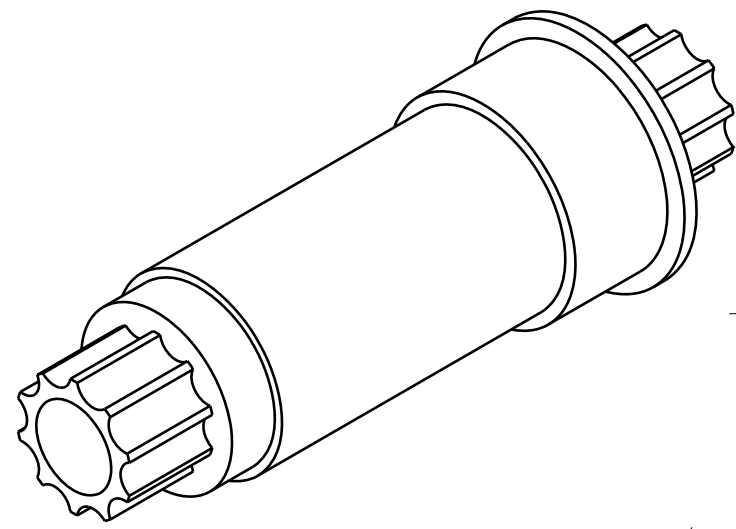

Isometric view
Scale: 1:1

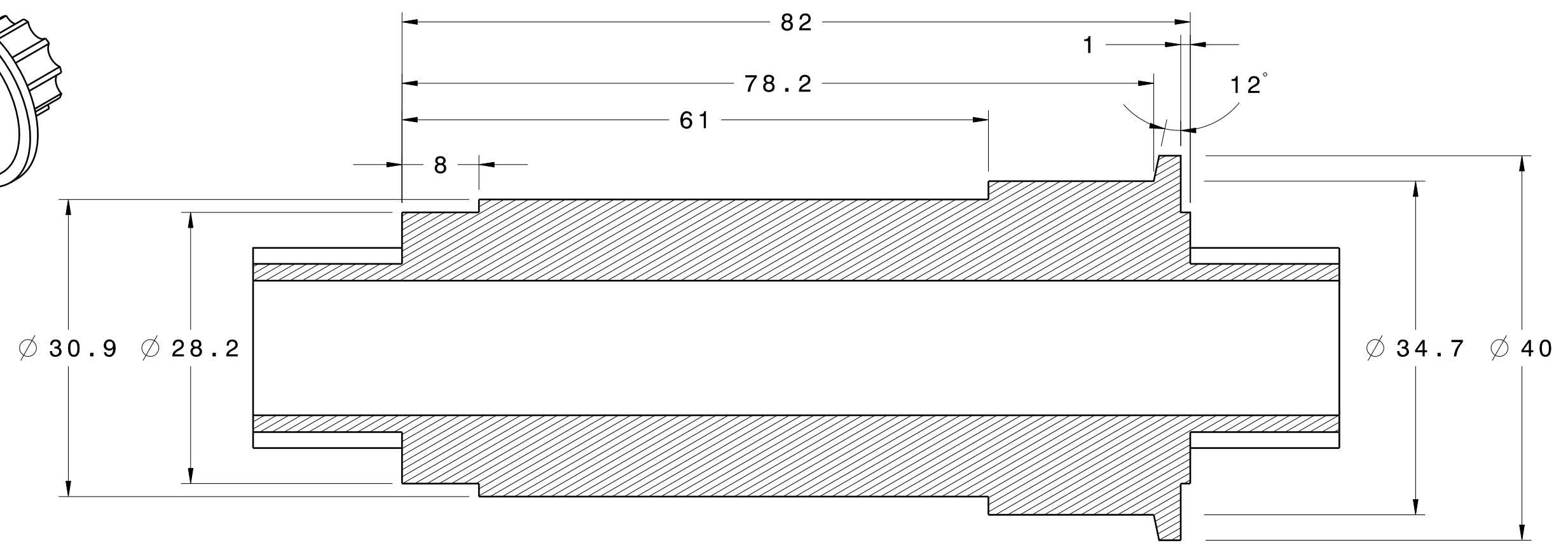

Section view A-A
Scale: 2:1

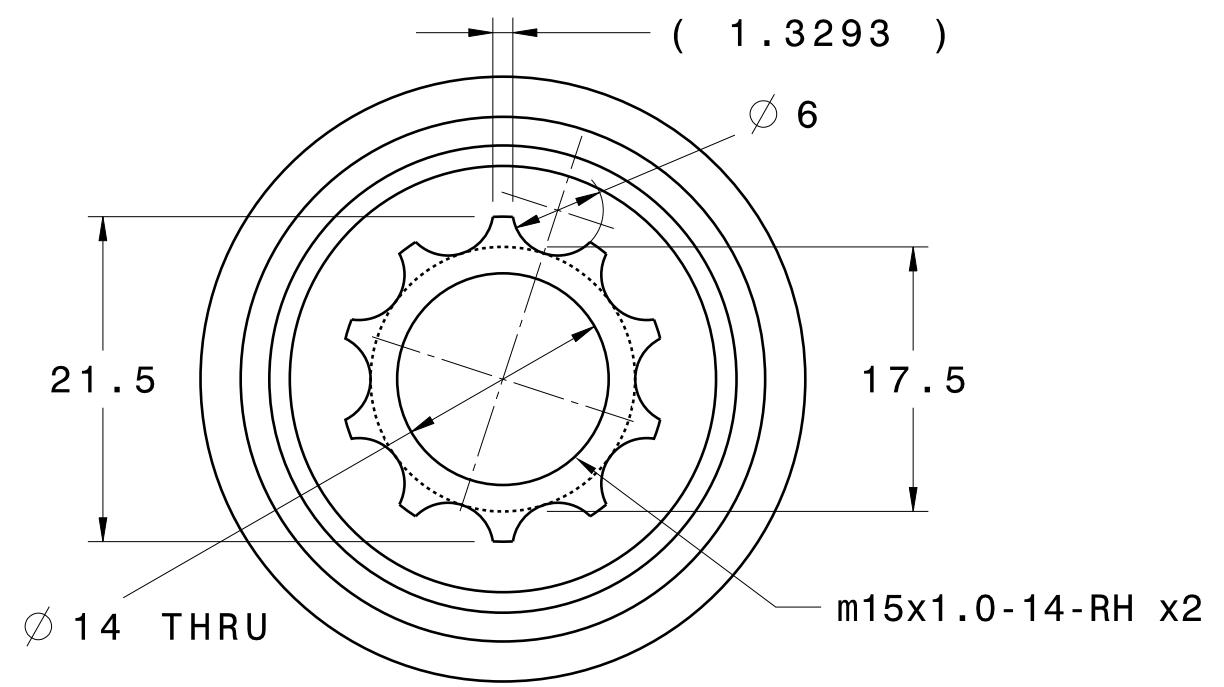

Left view
Scale: 2:1

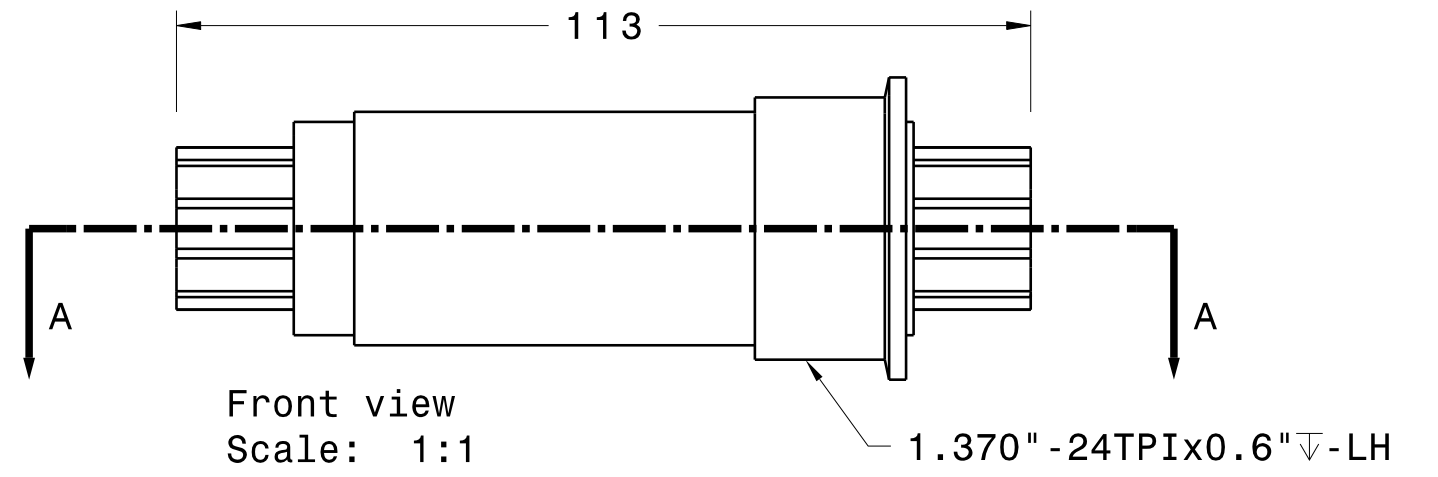

Front view
Scale: 1:1

Unless otherwise specified:
 X.X = ± 0.25
 X.XX = ± 0.13
 X.XXX = ± 0.03
 X° = ± 0.5°

www.StudyCAD.com
 Standard: ANSI B4.2 (ISO 286)

DRAWN BY Jerimiah		DATE 9/27/2013		DRAWING TITLE	
CHECKED BY XXX		DATE xxx		SIZE B	DRAWING NUMBER BottomBracketMain1
DESIGNED BY XXX		DATE xxx		SCALE 1:1	Units: mm
				SHEET 1/1	REV 1

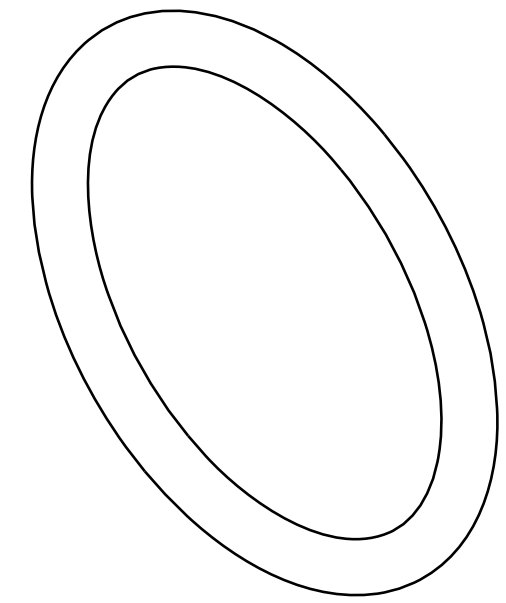
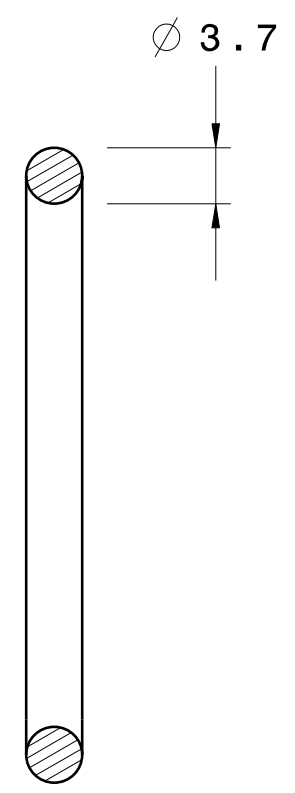
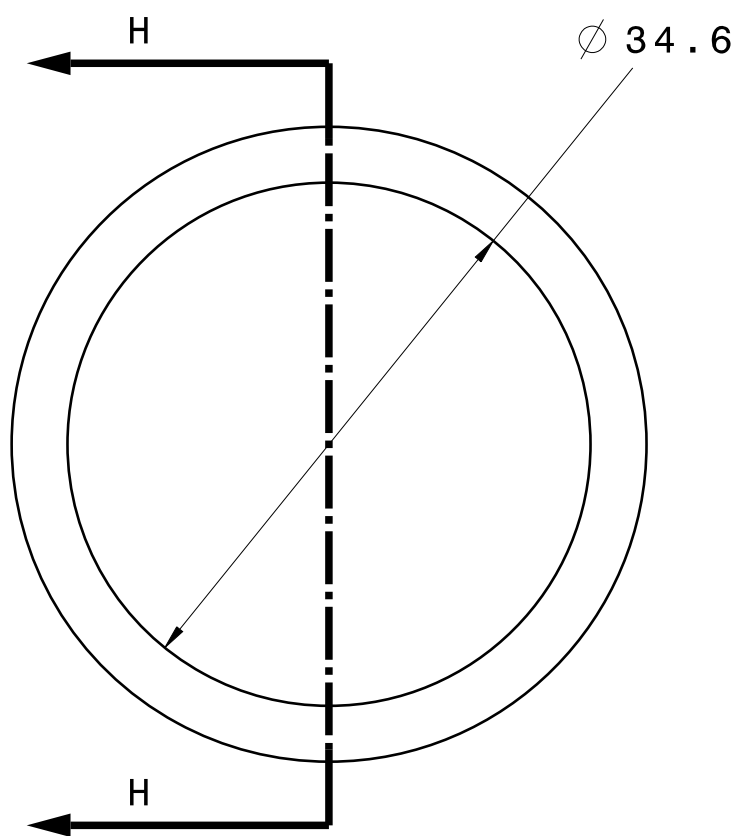

Unless otherwise specified: X.X = ± 0.25 X.XX = ± 0.13 X.XXX = ± 0.03 X° = ± 0.5°		www.StudyCAD.com			
		Standard: ANSI B4.2 (ISO 286)			
DRAWING TITLE					
DRAWN BY Jerimiah	DATE 9/27/2013	DRAWING NUMBER B BottomBracketOring1			REV 1
CHECKED BY XXX	DATE xxx	SIZE B	Units: mm		SHEET 1/1
DESIGNED BY XXX	DATE xxx	SCALE 2:1			

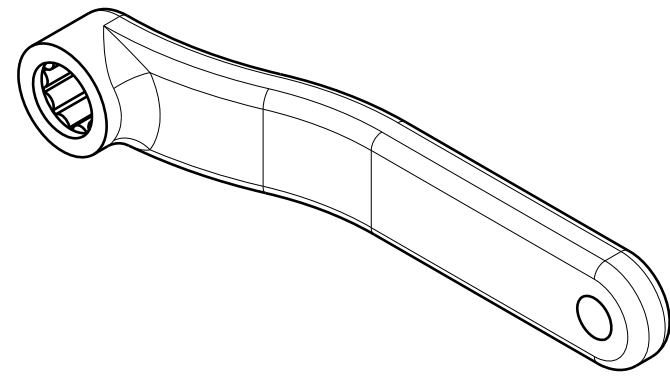

Isometric view
Scale: 1:2

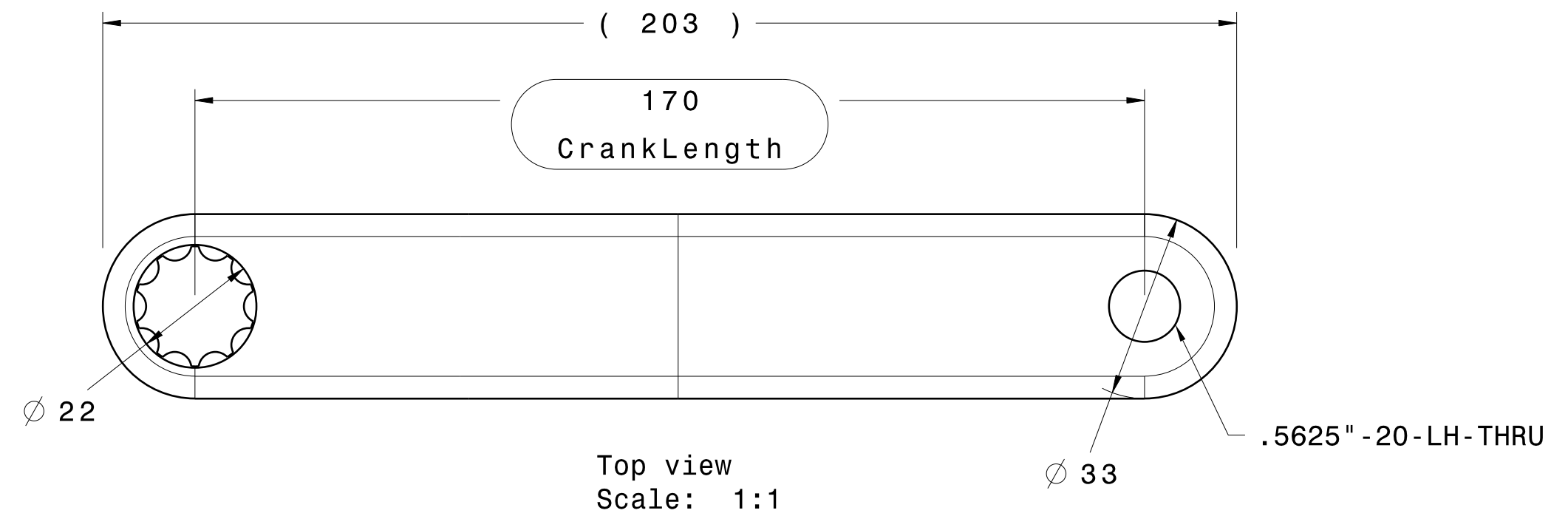

Top view
Scale: 1:1

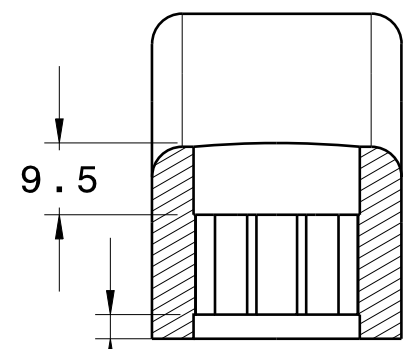

Section view E-E
Scale: 1:1

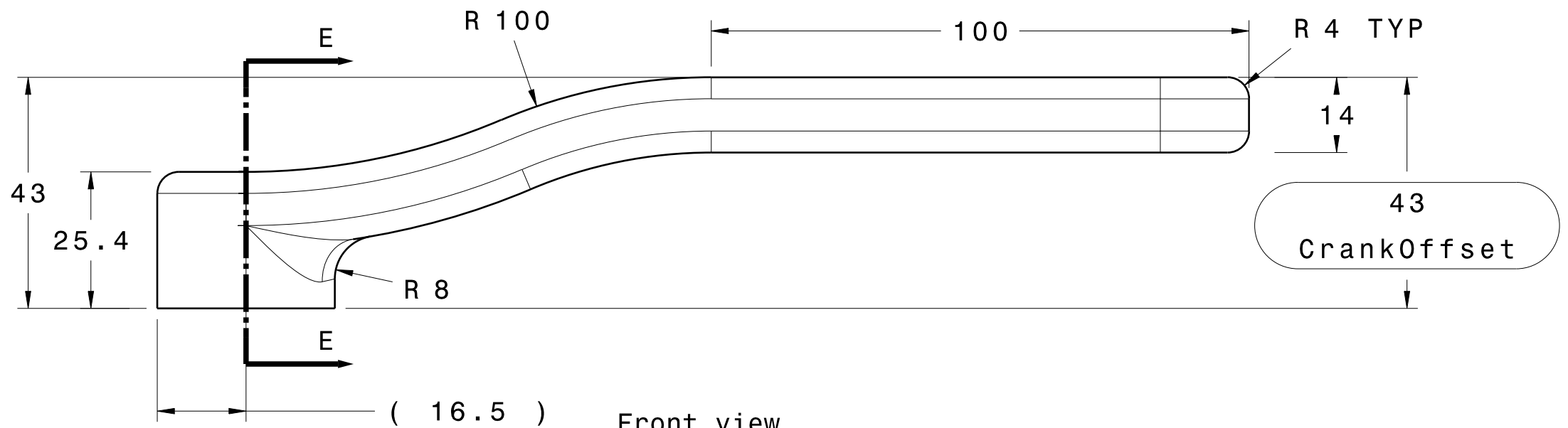

Front view
Scale: 1:1

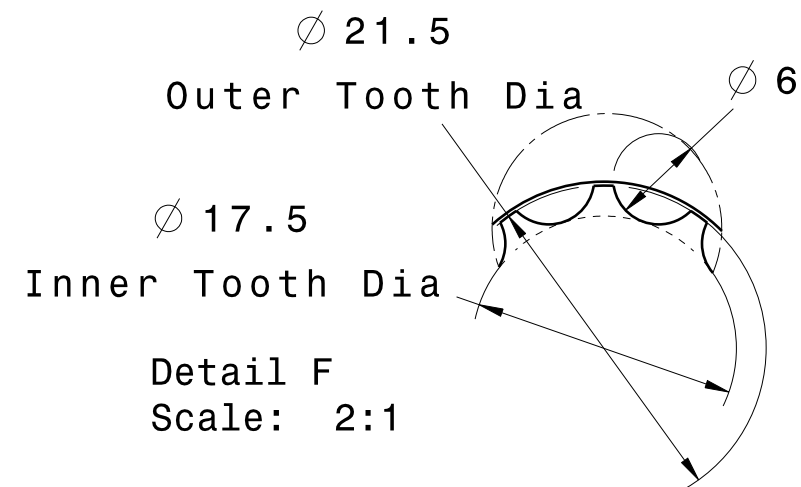

Detail F
Scale: 2:1

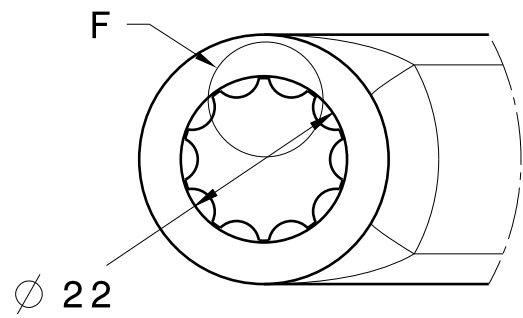

Bottom view
Scale: 1:1

Unless otherwise specified:
 X.X = ± 0.25
 X.XX = ± 0.13
 X.XXX = ± 0.03
 X° = ± 0.5°

www.StudyCAD.com
 Standard: ANSI B4.2 (ISO 286)

DRAWN BY Jerimiah	DATE 9/27/2013
CHECKED BY XXX	DATE xxx
DESIGNED BY XXX	DATE xxx

DRAWING TITLE			
SIZE B	DRAWING NUMBER LeftCrank1		REV 1
SCALE 1:1	Units: mm	SHEET 1/1	

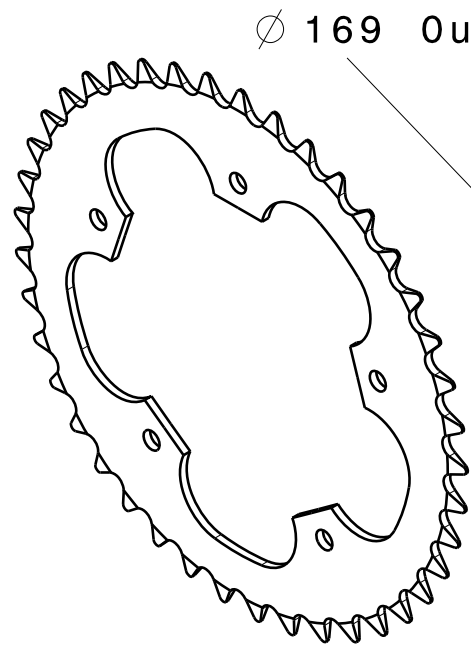

Isometric view
Scale: 1:2

Ø 169 Outer Tooth Dia.
Ø 154 Inner Tooth Dia.

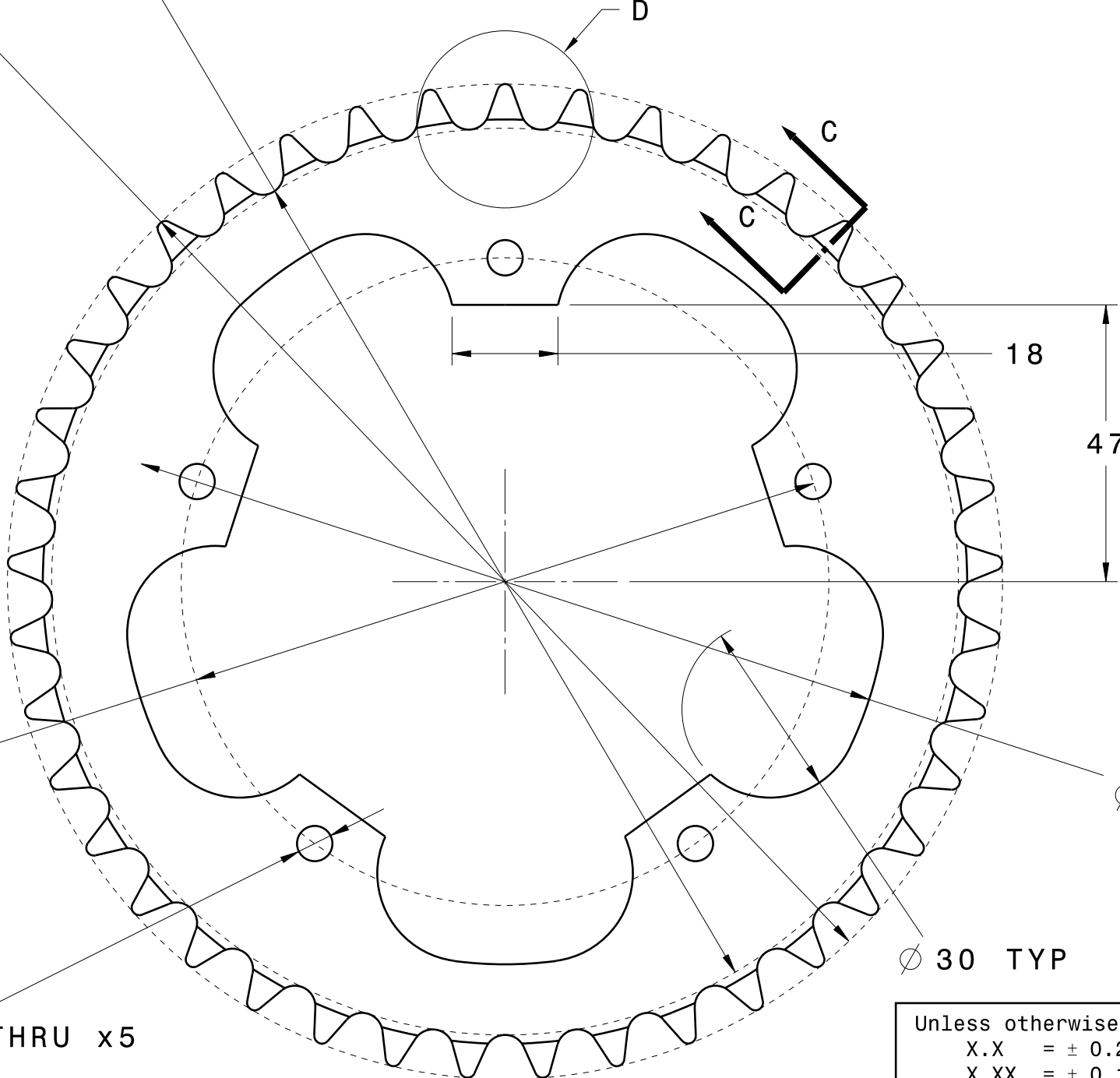

Front view
Scale: 1:1

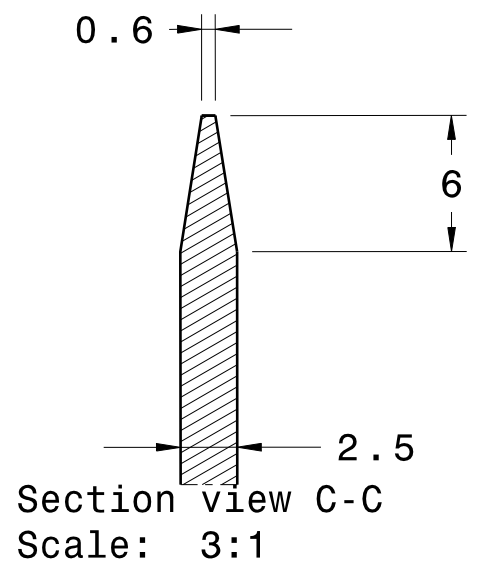

Section view C-C
Scale: 3:1

Note:
Tooth Side Line BiTangent
to upper and lower arcs

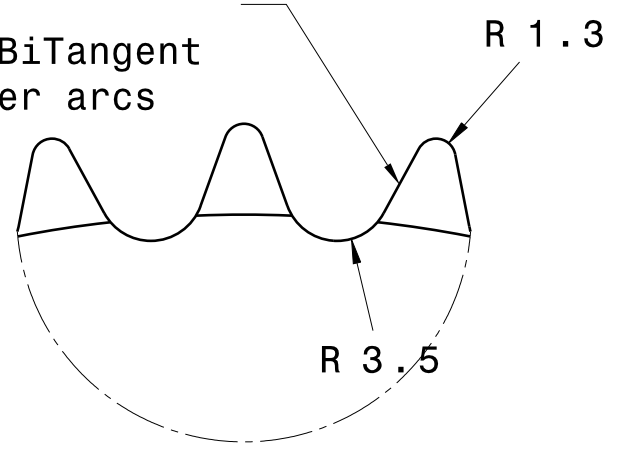

Detail D
Scale: 2:1

Ø 110 BCD

Ø 6 THRU x5

Ø 30 TYP

Ø 130

Unless otherwise specified:
X.X = ± 0.25
X.XX = ± 0.13
X.XXX = ± 0.03
X° = ± 0.5°

DRAWN BY Jerimiah		DATE 9/27/2013		www.StudyCAD.com		Standard: ANSI B4.2 (ISO 286)	
CHECKED BY XXX		DATE xxx		DRAWING NUMBER B		REV 1	
DESIGNED BY XXX		DATE xxx		SCALE 1:1		Units: mm	
DRAWING TITLE FrontChainring1				SHEET 1/1			

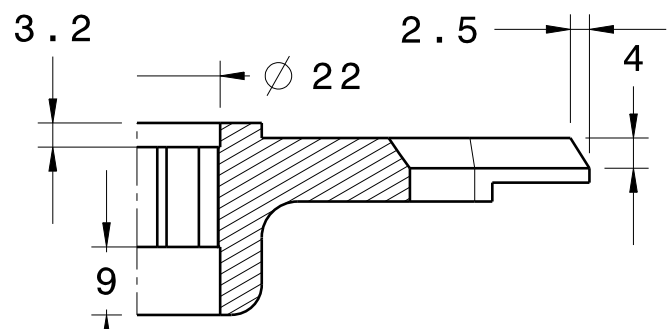

Section view J-J
Scale: 1:1

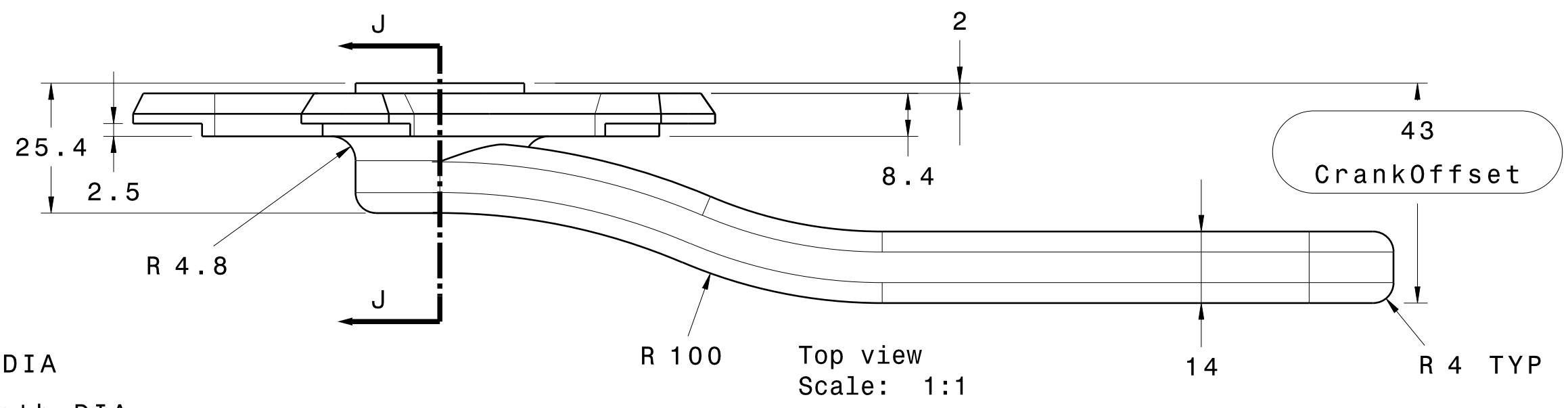

Top view
Scale: 1:1

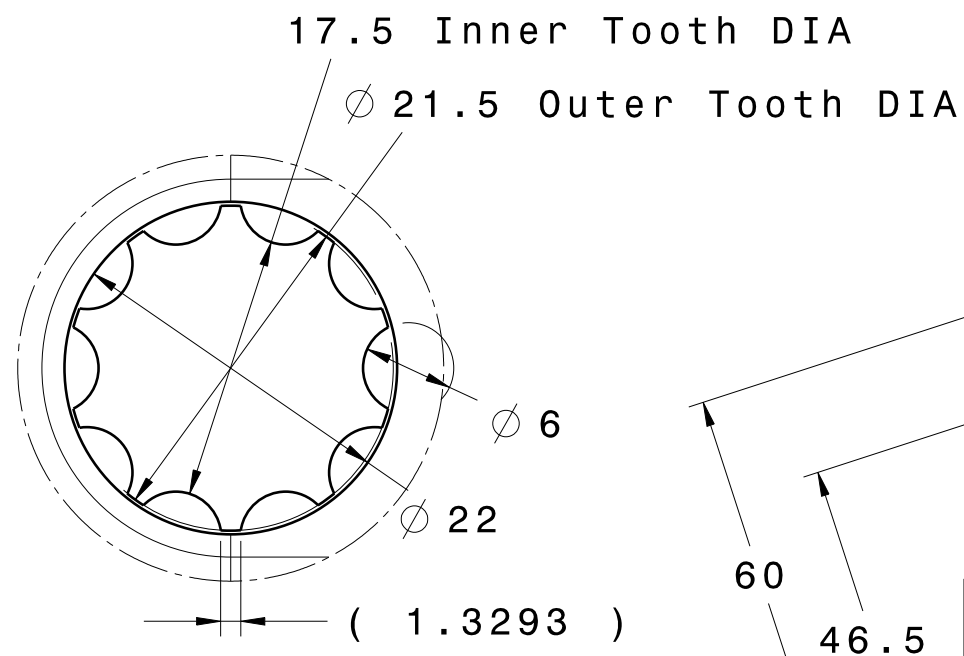

Detail I
Scale: 2:1

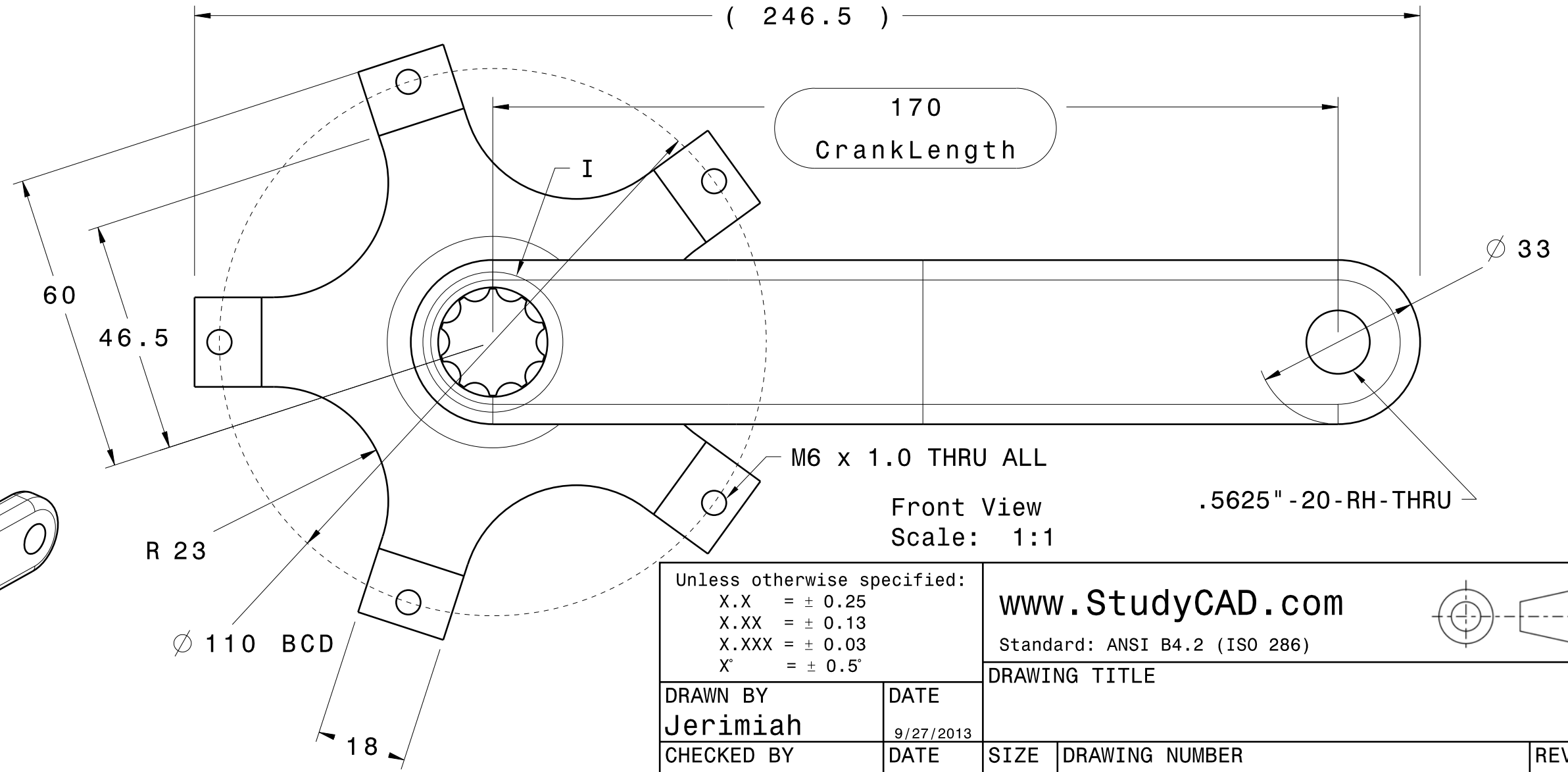

Front View
Scale: 1:1

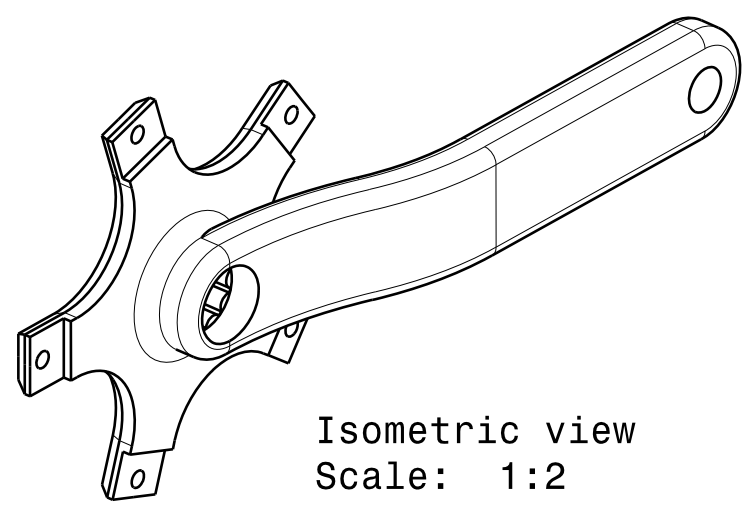

Isometric view
Scale: 1:2

Unless otherwise specified: X.X = ± 0.25 X.XX = ± 0.13 X.XXX = ± 0.03 X° = ± 0.5°		www.StudyCAD.com			
		Standard: ANSI B4.2 (ISO 286)			
DRAWN BY Jerimiah		DATE 9/27/2013		DRAWING TITLE	
CHECKED BY XXX		DATE xxx		SIZE B	DRAWING NUMBER RightCrank1
DESIGNED BY XXX		DATE xxx		SCALE 1:3	Units: mm
		SHEET 1/1		REV 1	

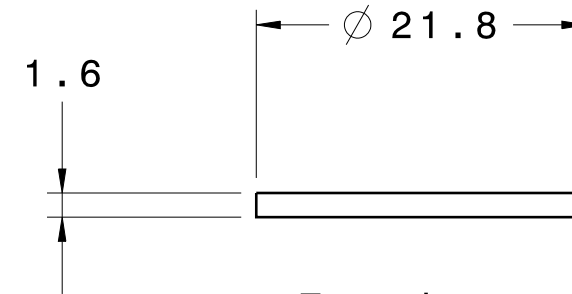

Top view
Scale: 2:1

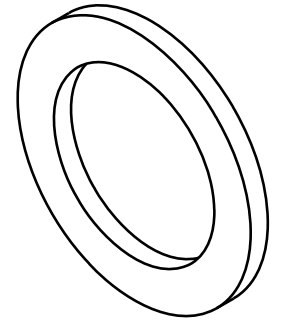

Isometric view
Scale: 2:1

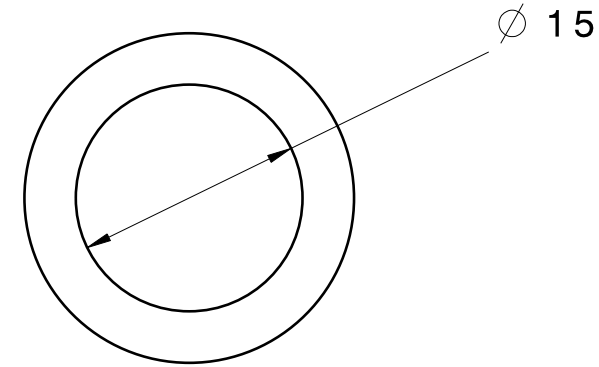

Front view
Scale: 2:1

Unless otherwise specified:
 X.X = ± 0.25
 X.XX = ± 0.13
 X.XXX = ± 0.03
 X° = $\pm 0.5^\circ$

www.StudyCAD.com

Standard: ANSI B4.2 (ISO 286)

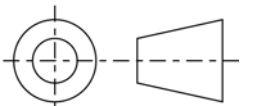

DRAWING TITLE

DRAWN BY
Jerimiah

DATE
9/27/2013

CHECKED BY
XXX

DATE
xxx

DESIGNED BY
XXX

DATE
xxx

SIZE B	DRAWING NUMBER CrankBoltWasher1	REV 1
------------------	---	-----------------

SCALE 2:1	Units: mm	SHEET 1/1
---------------------	-----------	---------------------

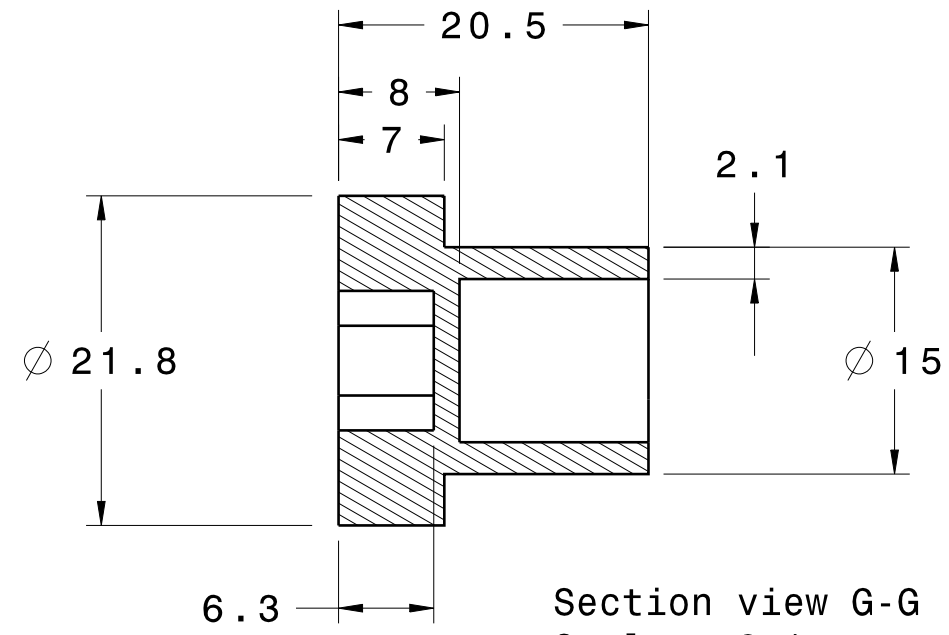

Section view G-G
Scale: 2:1

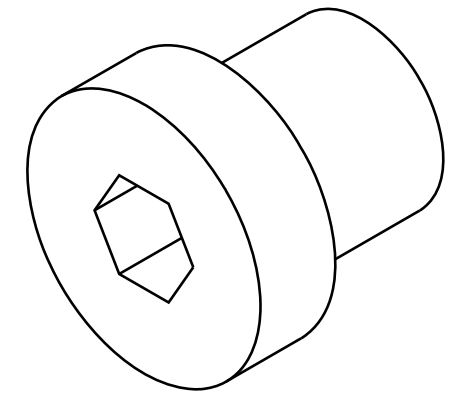

Isometric view
Scale: 2:1

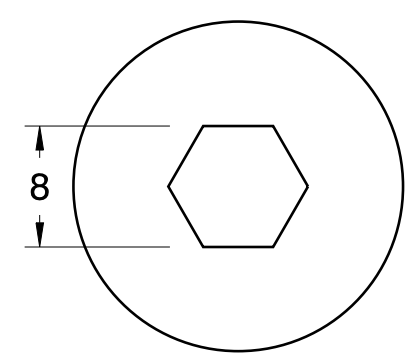

Left view
Scale: 2:1

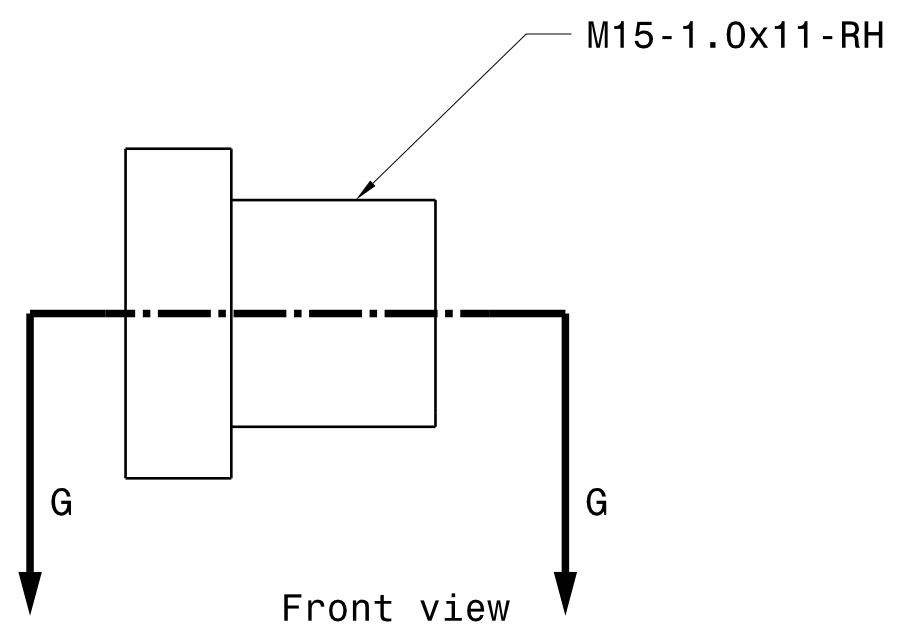

Front view
Scale: 2:1

Unless otherwise specified:
 X.X = ± 0.25
 X.XX = ± 0.13
 X.XXX = ± 0.03
 X° = ± 0.5°

www.StudyCAD.com
 Standard: ANSI B4.2 (ISO 286)

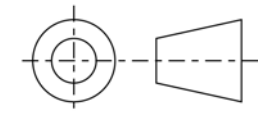

DRAWN BY Jerimiah		DATE 9/27/2013		DRAWING TITLE	
CHECKED BY XXX		DATE xxx		SIZE B	DRAWING NUMBER CrankBolt1
DESIGNED BY XXX		DATE xxx		SCALE 2:1	Units: mm
				SHEET 1/1	REV 1

Grading Rubric - Final Project

Drawing - CrankSetAssy1.pdf

Criteria	Ratings				Potential Pts	Earned Pts
Product Drawing Sheet (Exploded View, Other views, BOM, Part Balloons, Overall Dimensions, Title Block)	All Elements Present 10 pts	Some elements missing or incomplete 7 pts	Many elements missing or incomplete 4 pts	No Product Drawing 0 pts	10 pts	
Part Drawing Sheets	All Sheets Present in proper order 8 pts	All present, but wrong order 6 pts	Some missing 5 pts	No Part Drawing Sheets 0 pts	8 pts	
Part Title Blocks	All Present and Complete 8 pts	Some missing or incorrect 6 pts	Many missing or incorrect 3 pts	No title Blocks 0 pts	8 pts	
Part Views	All Present and Complete 8 pts	Some missing or incorrect 6 pts	Many missing or incorrect 3 pts	No Views 0 pts	8 pts	
Part Dimensions	All Present and Correct 10 pts	Some missing or incorrect 6 pts	Many missing or incorrect 4 pts	No Dimensions 0 pts	10 pts	
Part Tolerances	All Present and Correct 8 pts	Some missing or incorrect 6 pts	Many missing or incorrect 3 pts	No Tolerances 0 pts	8 pts	
Part Annotations (Hole Callouts, Notes)	All Present and Correct 8 pts	Some missing or incorrect 6 pts	Many missing or incorrect 3 pts	No Annotations 0 pts	8 pts	
Total Points: 60						0